

PHOSPHATE PRODUCERS IMPROVE PLANT PERFORMANCE USING

C.P.T. INC FLOTATION TECHNOLOGY

Harold E. Wyslouzil - P.Eng

President

Canadian Process Technologies Inc.

Vancouver, B.C. CANADA

Column flotation cells were introduced to the market place about thirty ago years as devices capable of producing concentrates that were lower in impurities than those produced by other types of flotation machines. The ability to operate columns with deep froth beds and the provision of froth washing systems were the main reasons cited for the improved metallurgical performance. In recent years, many Phosphate producers have installed CPT column flotation systems installations as a means of boosting production whilst reducing operating costs.

The mineral processing engineer is faced with many choices for the selection of processes and equipment when designing a new concentrator. For the flotation circuits there are many different types of machines available for use including conventional mechanically agitated cells, column cells, pneumatic cells, flash flotation cells etc. In many instances, characteristics of the ore will dictate whether or not certain methods can be applied. In other cases, economic considerations and personal preferences of the operators will prevail.

Metallurgical benefits can be derived in a number of ways. In some cases the metallurgical benefits may be obvious. Improved concentrate grades, improved recoveries and reduced reagent consumption are some of the benefits attributed to column cells. In other cases the benefits may be less clear. With some ores, for example, it is possible to recover a portion of the valuable mineral into a high grade concentrate directly at the rougher stage, thereby reducing the size of the subsequent treatment stages.

Operating cost savings can be realized from reduced power requirements, reduced maintenance costs and in some cases reduced reagent consumption.

- Power costs are typically 50% lower than an equivalent mechanical flotation circuit.
- Column cells have very low maintenance requirements and low inventory requirements.
- Reagent savings depend on the nature of the ore being treated and the reagent scheme being utilized. The most significant reductions usually occur with depressants, where it is possible to use wash water to lower impurity levels.

for the coarse circuit are reground and treated in yet another separate flotation circuit (regrind circuit, $d_{80} = 75 \mu\text{m}$). In all, there are five distinct flotation circuits each with a separate desliming section, conditioners and a rougher / cleaner flotation circuit with 2 to 3 stages of cleaning per circuit.

Some of the common problems encountered with the operation of the circuit which led this company to investigate the use of column flotation included:

- ***Continuous Release of Slimes***

Even after the ore has been well deslimed there is a tendency to release fresh slimes into the circuit. Many slimes are contained between the plates of the mica. The use of caustic soda in the circuit causes the plates to swell leading to the release of slimes. This process is accelerated by the intense agitation provided by the conditioners and mechanical cell agitators.

- ***High Reagent Consumption***

The use of fatty acid collectors often results in problems with control of the froth. The build-up of slimes in the circuit results in high collector consumption which makes the situation worse.

- ***High Re-circulating Loads***

The fine nature of the ore requires the use of multiple stages of cleaners to produce acceptable concentrate grades. The cleaner tails are re-circulated to the feed of the previous stage resulting in the development of large re-circulating loads. Control of the re-circulating loads is particularly important in the coarse and regrind circuits. The coarse rougher concentrate is devoid of fines and does not float well in the cleaners. In order to maintain acceptable recoveries in the coarse cleaning circuit the regrind second cleaner concentrate is combined with the coarse rougher concentrate for cleaning. This approach leads to a large re-circulating load through the regrind circuit and ultimately limits the total plant throughput.

A very enthusiastic test program was developed and executed over a seven month period. More than 3,000 tests were conducted using a 600 mm diameter test column equipped with a CPT industrial air sparging system and automatic controls. Every variable that affected the flotation performance was studied and optimized. The results of the test program were very good and a decision was taken to replace the existing mechanical cells with column cells according to the flowsheet shown in Figure 2.

The cell replacement program was completed in two phases. During the first phase, the natural fines circuit and the generated fines circuits were replaced by one column each. For the second phase, the barite flotation circuit and regrind flotation circuits were replaced by one column each and the coarse flotation circuit was replaced by two parallel columns. The total installation project was completed during routine maintenance shutdowns and did not result in any lost production.

The replacement program was extremely successful. The major benefits are summarized below:

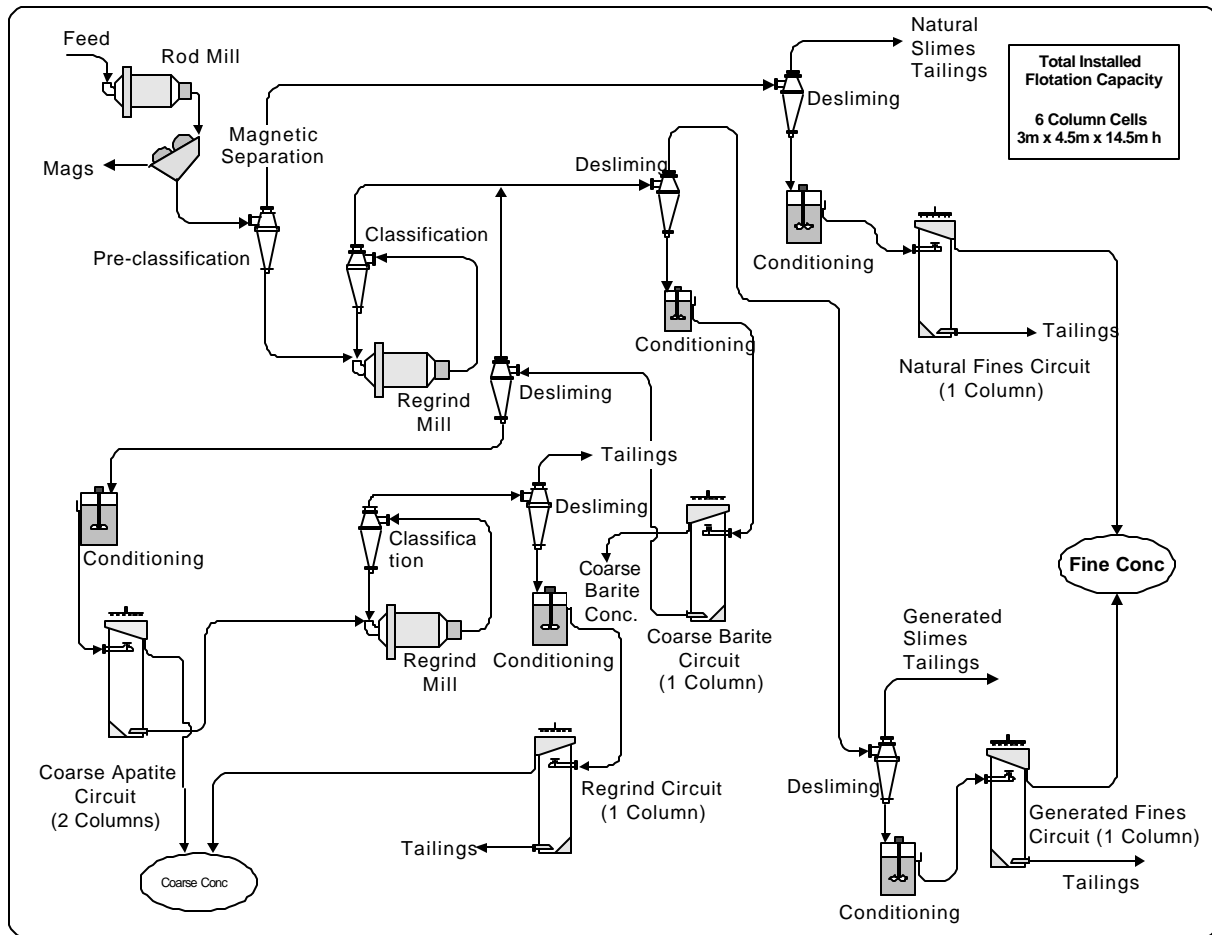

Figure 2 - Phosphate flotation circuit using CPT columns

- **Circuit Simplification**

Using column flotation it was possible to replace the rougher and two to three cleaner stages with a single column producing final concentrate. The total number of flotation cells was reduced from 64 - 300 ft³ Wemco cells to 6 - 3m x 4.5m rectangular column cells. Recirculating loads were reduced allowing an increased feed rate to the concentrator. Using the column cells, it is not necessary to add fines to the coarse cleaner circuit to achieve froth stability in the cleaners.

- ***Reduced Power Consumption***

The elimination of the mechanical flotation cells and associated pumps reduced the total concentrator power consumption by 15%. This figure includes the additional compressor power that was required for the column cells.

- ***Improved Metallurgical Performance***

The average increase in the concentrate grade was 2% P_2O_5 . Overall apatite recovery was 1% to 2% higher.

- ***Reduced Reagent Consumption***

The most significant benefit provided by the all column circuit was the reduction in the collector consumption. Improved froth characteristics in the column permitted the use of rice oil as an alternative to the fatty acid (rice oil could not be used with the mechanical cells due to excessive frothing). This change resulted in a decrease in the collector consumption of more than 90%.

- ***Reduced Slimes Generation***

The absence of mechanical agitation in the columns has reduced the level of new slimes generation within the flotation circuit and has simplified the operation of the circuit.

Column flotation has been applied to a wide variety of phosphate ore types ranging from volcanic to sedimentary. Although benefits are seen across the entire particle size range, column cells are particularly well suited to the production of fine and ultra-fine concentrates.