

## THE PRODUCTION OF HIGH GRADE IRON ORE CONCENTRATES USING FLOTATION COLUMNS

Harold E. Wyslouzil - P.Eng  
President  
Canadian Process Technologies Inc.  
Vancouver, B.C. CANADA

**Abstract** For many iron ore producers selling pellets in the highly competitive international market place, the ability to produce high quality products at low cost has become vitally important. A strong demand for low acid pellets suitable for direct reduction has resulted in an increase in the number of plants utilising reverse froth flotation for silica reduction. Column flotation is being favoured for this service due to the low capital and operating cost of the equipment, as well as, improved metallurgical performance when compared to conventional flotation cells. CPT Inc. has developed a flotation process for the production of Direct Reduction (DR) as well as Blast Furnace (BF) grade concentrates utilising column flotation technology. This process has been adopted by several major iron ore producers and current aggregate production is approximately 50 MTPY of DR grade concentrates.

This paper describes the benefits of column flotation and discusses some important aspects of circuit design.

**Keywords** Column flotation, iron ore, column tests, silica, froth flotation,

## Introduction

The depletion of high grade reserves coupled with increasing market pressure for improved product quality has forced iron ore producers to re-examine their process flowsheets and evaluate alternate or supplemental processing routes. The requirement for higher quality pellets demands that the silica content be lowered to levels ranging from 2.0% SiO<sub>2</sub> to below 1.0% SiO<sub>2</sub>. Reverse flotation (silica is floated away from the iron concentrate) has proven to be an economical and effective method for reducing the concentrate silica content to very low levels. Laboratory and commercial test-work has demonstrated some significant metallurgical and economic advantages when column flotation cells are used for this application.

Excellent metallurgical performance [1,2,3] along with low capital and operating costs [3] have made column flotation popular in the mineral processing industry. For iron ore applications, the ability to wash the froth has provided a means for obtaining low concentrate silica levels while keeping iron losses to a minimum. Recent cost comparisons[4] have shown that the cost of installing a column flotation circuit is typically 20% - 30 % less than an equivalent conventional flotation circuit but can be as much as 50% lower depending on the circuit and plant location.

The Brazilian iron ore industry has led the world in adopting column flotation technology for reducing the silica content of iron pellets[5]. Several companies have installed, or are in the process of installing column cells into their process flowsheets. Samarco Mineracao S.A., the first Brazilian producer to use column cells, installed columns to increase flotation capacity as part of a plant expansion program[4] in 1990. Since that time, they have installed additional columns for the recovery of fine iron from the desliming circuit and for a recent plant expansion program. Table - 1 lists the major users of column flotation in iron ore applications.

*Table 1: List of major users of column flotation in iron ore applications*

Company	Service	Qty	Size	Application
Samarco	Recleaners	3	3m x 6m x 13.6m	Silica reduction from itaberite
	Recleaners	4	3.67m x 13.6m	Silica reduction from itaberite
	Scavengers	2	3m x 4m x 13.5m	Silica reduction from itaberite
	Scavengers	1	2.44m x 10m	Silica reduction from itaberite
	Rougher	1	3m x 4m x 12m	Silica reduction from itaberite
	Cleaner	1	3m x 2m x 12m	Silica reduction from itaberite
MBR	Rougher	2	3.67m x 14m	Silica reduction from hematite
	Cleaner	1	3.67m x 14m	Silica reduction from hematite
Samitri IB-II	Rougher	2	2.44m x 12m	Silica reduction from hematite
	Cleaner	1	2.44m x 12m	Silica reduction from hematite
Samitri IB-III *	Rougher	1	4m x 12m	Silica reduction from itaberite
	Cleaner	1	4.5m x 12m	Silica reduction from itaberite
	Scavenger	2	4.5m x 8m	Silica reduction from itaberite
CSN	Rougher	3	4m x 10m	Silica reduction from itaberite
	Scavenger	1	4m x 10m	Silica reduction from itaberite
CVRD Timbopeba	Rougher	2	4m x 15m	Silica reduction from itaberite
	Cleaner	1	4m x 15m	Silica reduction from itaberite
CVRD Conceicao	Rougher	6	3m x 5m x 14m	Silica reduction from itaberite
	Cleaner	3	3m x 5m x 14m	Silica reduction from itaberite
Kudremuhk	Rougher	2	4m x 12m	Silica reduction from magnetite
	Rougher *	6	4m x 12m	Silica reduction from magnetite
Minera Del Norte	Cleaner	2	4m x 10m	Phosphorous reduction from hematite
USS Mintac *	Cleaner	4	3.67m x 12m	Silica reduction from taconite

\* - Projects currently under construction or columns supplied by others

The application of column flotation for silica rejection is being actively investigated by several iron ore companies in Brazil, Canada, the United States, Venezuela, and India.

The purpose of this paper is to describe some of the benefits of column flotation, and to discuss some of the important aspects of circuit design.

## Benefits of Column Flotation

Column flotation has become widely accepted throughout the minerals industry[6]. It is no longer considered to be new or risky technology and many new concentrators have incorporated column cells into the flowsheet.

The main benefits for column flotation can be summarised as follows:

- Improved metallurgical performance
- Low capital cost
- Low maintenance costs (no moving parts)
- Superior control and stability due to the adaptability to automatic controls

An example of the metallurgical benefits of column flotation are demonstrated in Table 2. This table compares test results for the production of direct reduction grade concentrate using a conventional mechanical cell circuit and a column flotation circuit.

**Table 2 : Pilot Scale Test Data for Production of DR Concentrate**

	Mechanical Cells	Column Cells
Feed Grade (% Fe)	56.87	55.40
Feed Grade (% SiO <sub>2</sub> )	15.07	18.30
Concentrate Grade (% Fe)	67.84	66.95
Concentrate Grade (% SiO <sub>2</sub> )	0.76	0.82
Mass Recovery (%)	66	71
% Fe Recovery	79.5	87.5

In a recent study comparing the capital costs for a 620 tph flotation plant for treating iron ore fines, the following equipment requirements were identified.

### Mechanical Circuit

#### Circuit Configuration: Rougher with two stages of scavenging

Number of Wemco 500 ft <sup>3</sup> Cells		
	BF	DR
Rougher	16	16
Scavenger 1	10	16

Scavenger 2	9	12
Total	35	44

## Column Circuit

### Circuit Configuration: Rougher and Cleaner

Number of 4m x 10m Columns		
	BF	DR
Rougher	3	3
Cleaner	0	1
Total	3	4

Based on these flotation requirements, the capital cost for equipment (including electrical), metal structures and concrete was determined. The costs are summarised in Table 3. It should be noted that these costs relate only to the flotation section and do not include the costs for conditioners, and pumps which would be common to both systems.

**Table 3: Investment Requirements: Mechanical Cells Vs. Column Cells**

Description		Mechanical Cells		Column Cells	
		Qty	Cost (\$US)	Qty	Cost (\$US)
Equipment	Flotation Cells	44	\$1,760,000	4	\$380,000
	Compressor	-	-	3	\$240,000
Metal Structure (Fabrication and erection)		200t	\$500,000	65t	\$162,000
Civil Works	Concrete	416 m <sup>3</sup>	\$232,000	240 m <sup>3</sup>	\$133,000
	Foundations	144t		83t	
<b>Total</b>			<b>\$2,492,000</b>		<b>\$915,000</b>

There are several features of flotation columns which promote greater separation efficiency. Some of these features include:

- Cell geometry
- Froth washing
- Highly controllable air sparging system

## Cell Geometry

The geometry of flotation column offers some advantages over conventional cells. Column cells have a much smaller surface area per unit volume of capacity than conventional cells which promotes froth crowding. This results in higher froth densities, and when coupled with a stabilizing water addition, permits froth depths of 1m - 2m to be maintained. The deep froth allows for better drainage and gives the operator more flexibility in controlling the grade/recovery relationship. Another advantage of the column geometry is that slurry flows through the cell by gravity. This permits the cells to be operated at feed densities higher than those in conventional cells and provides a greater tolerance to the presence of coarse particles.

## Froth Washing

The froth washing system on flotation columns serves two purposes. The first is to provide water for froth stabilization and the second is to displace the process water which normally discharges with the froth. By maintaining a flow of wash water slightly greater than what is required to transport the froth out of the cell (positive bias condition), process water and hydrophilic particles trapped in the froth zone can be effectively washed back into the collection zone. This feature is one of the major reasons for improved metallurgical performance.

## Air Sparging

Air sparging systems for column cells have undergone numerous refinements over the years and modern day systems provide means for regulating bubble size as well as aeration rate. The ability to regulate bubble size allows columns an additional advantage over conventional flotation equipment by allowing the bubble size distribution to be optimised for the material being treated.

## *Circuit Design Considerations*

The integration of column flotation into existing iron ore plants can be done in a number of different ways depending on metallurgical and economic objectives. Some of the common objectives are:

- Incorporate flotation into a plant presently using other concentration methods to permit the production of low silica pellets.
- Increase the flotation capacity of an existing plant.
- Improve the overall plant iron recovery by re-treatment of the tailings.
- Install a circuit capable of producing more than one product grade.

Many plants require the flexibility to produce more than one product grade (eg blast furnace and direct reduction) using the same equipment. Usually when the higher silica blast furnace products are produced, the grinding requirements for liberation decrease and therefore the plants can operate at increased throughputs. The higher feed rate will affect the feed size distribution and must be taken into in the circuit design.

The following examples show some of the flowsheet configurations which have been adopted by iron ore producers.

### *Example I: Cleaner - Scavenger Circuit*

For this Brazilian flotation plant, the original circuit consisted of four parallel mechanical flotation lines containing a rougher, cleaner, and two scavenging stages. The depletion of reserves at the existing mine and the subsequent development of a new ore zone necessitated the modification of the flowsheet[6] since ore from the new mine is more difficult to grind and requires longer flotation time.

A number of circuit alternatives were considered:

- 1) Installation of an additional line of conventional cells
- 2) Increasing flotation capacity by installing a line of column cells
- 3) Adding column cells to existing flotation lines to act as recleaners

Pilot plant results revealed that the third option provided the best combination of plant throughput and iron recovery. The flowsheet for the modified circuit is shown in Figure 1.

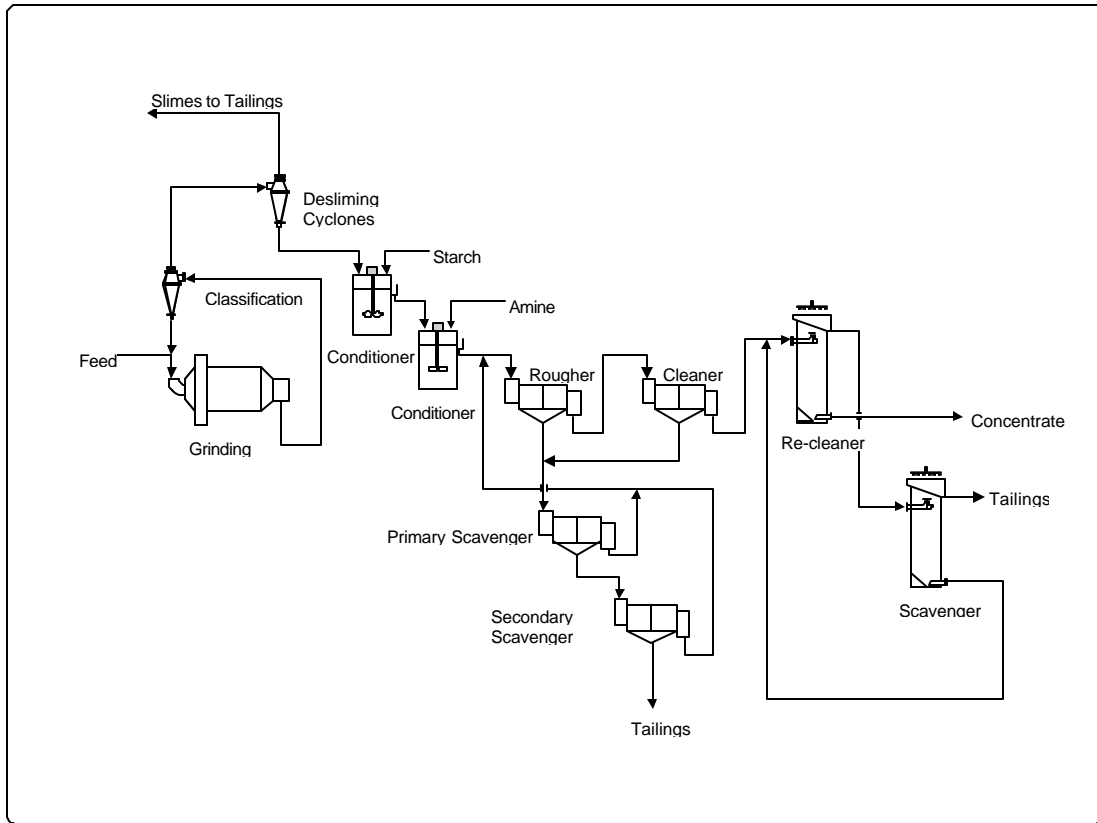

**Figure 1 : Columns added to an existing circuit**

One column has been added as a recleaner to each processing line to preserve circuit flexibility. The recleaner column feed grade ranges between 1% and 6% silica, therefore, one column stage is sufficient to produce either blast-furnace or direct-reduction concentrate.

A scavenger column has been added to the flowsheet to maximize fine iron recovery particularly during the periods where direct reducing grade is being produced. Because these columns have been added to an existing silica flotation plant as recleaners, consideration needs to be given to the effects of variations in the roughing and primary cleaning circuit. Generally the fine, fast floating silica is removed in the roughing stage and therefore the column feed tends to be enriched in coarse silica. Furthermore, any operational problems with the existing plant tend to flow through to the column circuit resulting in variable feed conditions.

The flotation rate constant for the silica particles is affected by feed grade and particle size. Many iron ore concentrators use the quantity of +.15 mm (100 mesh) material in the flotation feed as a measure of the performance of the grinding circuit. This particle size is well within the normal size range for flotation and presents no particular problems. Particles larger than .30 mm (48 mesh) however become increasingly difficult to float and to retain in the froth phase.

For plants using hydrocyclones for classification, the distribution of silica is not even throughout the particle size range. The silica often tends to concentrate in the coarser size fractions. As the amount of +.15 mm in the feed increases the quantity of +.30 mm tends to increase exponentially thus compounding the problem. The relationship between the quantities of +.15 mm and +.30 mm in the column feed is shown in Figure 2. Particles in the +.30 mm size range produce relatively poor response with maximum recoveries often below 50%. In a column the slurry falls by gravity through the collection zone. Consequently the coarser particles settle at a rate higher than the average slurry. For example, if the mean slurry residence time is 12 minutes, the residence time of the +.30 mm particles could be 6 - 8 minutes depending on the slurry rheology within the collection zone. Therefore, when considering columns for this type of application it is important to have a good understanding of the

degree of variation of particle sizes in the existing circuit to permit proper sizing of the column circuit.

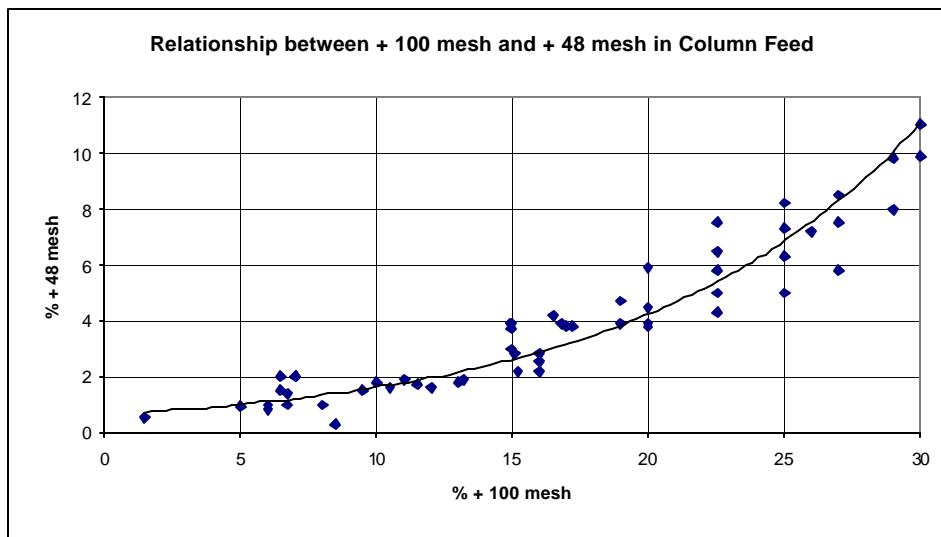

Figure 2: Relationship between + 100 mesh and + 48 mesh particles in flotation feed

### *Example II: Rougher - Cleaner Circuit*

For another project, a column flotation circuit is being constructed as an addition to an existing plant to recover fine iron from a tailings stream. The existing plant currently produces -25mm + 6mm blast furnace feed and -6mm + .10mm sinter feed. The objective of the new plant is to treat the plant tailings (-.10mm fraction) to produce both blast furnace and direct reduction grade pellet feed. The specifications for the plant require that a blast furnace concentrate containing 1.7 - 2.0 % SiO<sub>2</sub> and a direct reduction concentrate containing 0.8 - 1.0 % SiO<sub>2</sub> be produced for feed grades ranging from 13 - 20% SiO<sub>2</sub>. Originally, the plant flowsheet was based conventional flotation machines. Pilot plant column tests however, produced consistently higher iron recoveries than the mechanical cells and thus the decision was made to select column cells in the final design.

Columns are designed to work within a specific range of flows which balance the residence-time constraints of high flows and the froth stability problems associated with low flows. Furthermore, for situations requiring high mass recovery to the froth phase, the limitations of carrying capacity, air loading and lip loading may supersede residence time requirements. In this case, the two parallel rougher columns are designed to operate with all three, or any two, of the parallel desliming circuits which feed the columns. One column may be taken off-line in the single feed stream scenario.

Internal mixing and inefficiencies in operational practice usually limit column stage-recovery. To ensure that concentrate grade requirements could be achieved for all forecasted feed conditions, a closed rougher/cleaner circuit was recommended. This configuration allows the rougher to be operated in a manner which will ensure minimum iron losses to tails. The cleaner cell will ensure that the silica content remains within specifications. Froth from the cleaner stage is recycled to the rougher to recovery any entrained iron. A simplified flowsheet of the circuit is shown in Figure 3. This configuration provides the ability to produce either concentrate, from any combination of streams, and the flexibility of adding a regrind stage if liberation becomes a factor in the future.

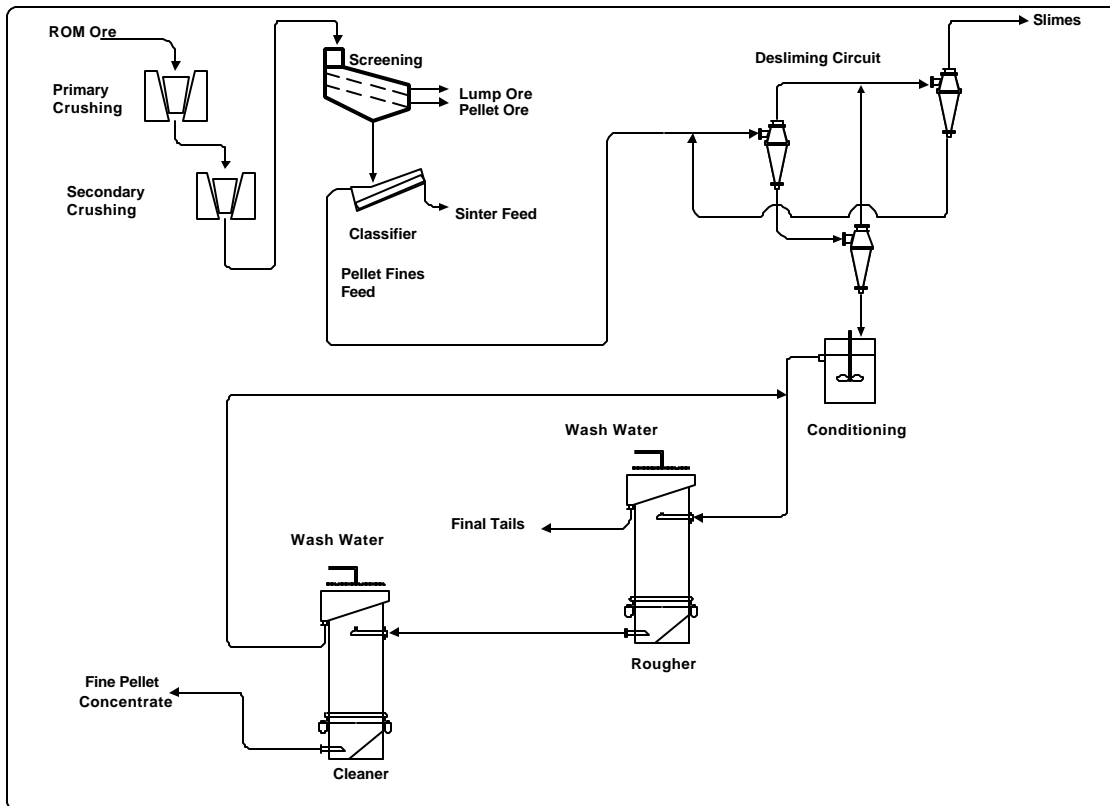
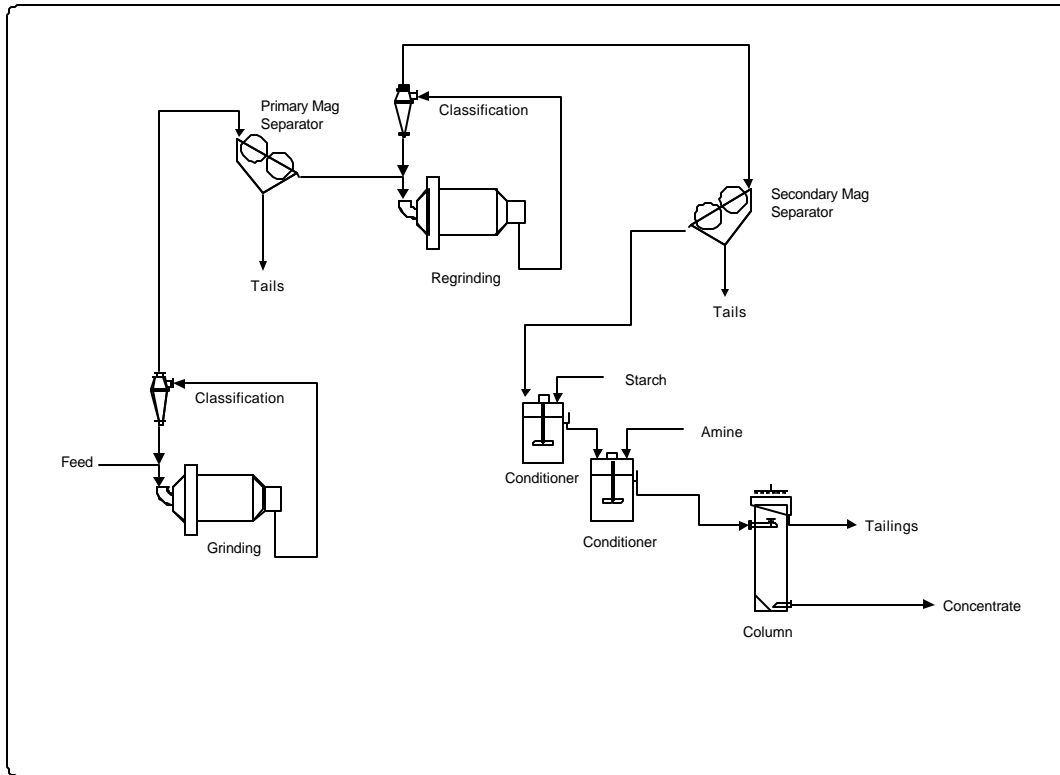

**Figure 3: Rougher - Cleaner Circuit**

### Example III- Silica Reduction from Magnetite Concentrate

CPT Inc. has recently completed the basic engineering for a 1180 TPH flotation plant designed to lower the silica content of a magnetite concentrate from 7% - 9% SiO<sub>2</sub> to 2.2% SiO<sub>2</sub>. The basic flowsheet is shown in Figure 4. New feed is ground to 80% passing .15 mm (100 mesh) and is fed to primary magnetic separators. The magnetic concentrate is reground to approximately 75% -.045mm (325 mesh) and is retreated in secondary magnetic separators which produce a concentrate containing between 7% - 9% SiO<sub>2</sub>. The magnetic concentrate is conditioned first with caustic starch solution and then with amine prior to being fed to a single stage flotation column where the silica content is reduced to below 2.2% SiO<sub>2</sub>.

The ore is highly variable in magnetite content and therefore it was necessary to design the circuit to tolerate large fluctuations in feed rates. A high level of instrumentation has been specified to provide on-stream analysis, automatic reagent metering and the ability to switch groups of columns into "hot stand-by" mode. During periods of decreasing feed rates, individual columns will be by-passed, the reagent addition stopped and the columns placed in recycle mode. When the feed increases to normal levels, the process is reversed and the columns resume normal operation.



**Figure 4: Column Flotation Circuit For Magnetite Treatment**

## Conclusions

Many iron-ore producers world-wide are considering columns as a viable alternative to conventional flotation machines for the reduction of silica in fine pellet feed.

The ability to operate with wash water and deep froth beds results in improved iron recoveries particularly when producing direct reduction grade concentrate.

The circuit chosen is dependent on the range of flows the column is required to handle and the metallurgical performance expected. A large range of flows, tonnage, or grades may require multiple parallel columns rather than a less expensive, single, large column. Depending on the metallurgical objectives and the degree of upgrading required, columns circuits may be configured as a rougher and cleaner or as a cleaner and scavenger.

The complex nature of three-phase vessels, the variability in ore and plant operations mean that a good understanding of the variability of the proposed column circuit feed is essential in order to properly size the columns.

## References

- 1.Cienski, T., and Coffin, V., Column Flotation Operation at Mines Gaspé Molybdenum Circuit, *13<sup>th</sup> Annual CMP Conference*, Ottawa, Jan. 20-22 (1981).
- 2.Coleman, R., and Kilgour, I., The Installation of a Final Cleaning Column at Ok Tedi, *Fourth Mill Operators' Conference*, Burnie, Tas 10-14 March (1991).

3. Smithson, E.P., John, C.I.A., Rea, T.H., and Mwenya, W.M., Improving Concentrate Quality in the Concentrators of Zambia Consolidated Copper Mines Limited Using Column Cells. *Column 91, Int. Conf. on Column Flotation*, Sudbury, June 2-6 (1991).
4. Viana, P.R.M., Silva, J.P., Rabelo, P.J.B., Coelho, A.G., and Silva, V.C., Column Flotation for the Expansion of the Flotation Circuit at Samarco Mineracao, Brazil. *Column 91, Int. Conf. on Column Flotation*, Sudbury, June 2-6 (1991).
5. Murdock, D.J., Tucker, R.J., and Jacobi, H.P., Column Cells VS. Conventional Flotation, A Cost Comparison. *Column 91, Int. Conf. on Column Flotation*, Sudbury, June 2-6 (1991).
6. Sandvik, K.L., Nybo, A.S., and Rushfeldt, O., Reverse Flotation to Low Impurity Levels by Column Flotation. *Column 91, Int. Conf. on Column Flotation*, Sudbury, June 2-6 (1991).
7. Levenspiel, O., *Chemical Reaction Engineering*, Wiley, N.Y., Chap. 9 (1972).
8. Finch, J.A., and Dobby, G.S., *Column Flotation*, Pergamon Press, Toronto, Chap. 4 (1990)
9. Xu, M., Uribe-Salas, A., Finch, J.A., and Gomez, C.O., Gas Rate Limitations in Column Flotation, in *Processing of Complex Ores*, (Ed. G.S. Dobby S.R. Rao), Pergamon Press, Toronto (1989).
10. Flint, I.M., *Bubble Generation in Flotation Columns*, M.A.Sc. Thesis, University of Toronto (1989).
11. Yianatos, J.B., Finch, J.A., and Laplante, A.R., Apparent Hindered Settling in a Gas-Liquid-Solid Countercurrent Column. *Int. J. of Min. Proc.*, vol 18, No 3/4, Nov (1986).
12. Ityokumbul, M.T., A New Modelling Approach to Flotation Column Design, *Minerals Engng*, Vol 5., no. 5/6 (1992)
13. Amelunxen, R.L., Column Flotation: New Carrying Capacity Considerations for Scale-up. *Expomineria 90'*, Santiago Chile. May 14-18 (1990).
14. Rasemann, W., On the Attachment Probability of Bubble/Particle Contacts in Solid/Liquid Suspensions. *Int. J. of Mineral Processing*, vol 24, 247-267 (1988).
15. Szatkowski, M., and Freyberger, W.L., The Effect of Bubble Size Distribution on Selectivity of Iron Ore Flotation. *Int. J. of Mineral Processing*, vol 23, 213-227 (1988).
16. Ahmed, N., and Jameson, G.J., The Effect of Bubbles size on the Rate of Flotation of Fine Particles. *Int. J. of Mineral Processing*, vol 14, 195-215 (1985).
17. Bach, H.F., and Pilhofer, T., Variation of Gas Holdup in Bubble Columns with Physical Properties of Liquids and Operating Parameters of Columns. *Ger. Chem. Eng.* vol 1, 270-275 (1978).
18. Yianatos, J.B., Espinosa, R.G., Finch, J.A., and Laplante, A.R., Effect of Column Height on Flotation Performance, *AIMED* Denver Colorado, Feb. 24-27, (1987).